

SQ2 Sanitary Sample Cooler

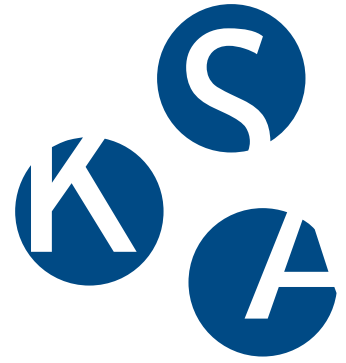

Keith Shuttleworth
& Associates

*Is your cooler
specification higher
than the system being
tested?*



Product features

- Designed specifically for taking high quality chemistry/TOC, conductivity and microbiological samples safely from steam or heated recirculating water systems.
- The use of high quality materials reduces the risk of sample contamination. All sample contact surfaces are electropolished 316L stainless steel with Ra 0.25 μm (10 μin) surface finish.
- The heat exchanger coil is self-draining.
- Fully traceable materials are used - a full certification package is provided for all sample contact surfaces.
- 100% 316L stainless fabrication with bright polish finish.
- Easily cleaned and compact sanitary design to allow it to be located in clean areas. The compact design requires a minimum of space.
- Sample outlet suitable for flaming.
- The counter current flow makes the cooler efficient.
- Designed for either wall mounting using integral 316L stainless steel brackets with space to allow cleaning behind, or for portable applications where screw in legs are provided.
- Both fixed and portable models are designed to be steam sterilized (or dry heat sterilized / depyrogenated).
- Supplied with comprehensive operating and safety instructions.



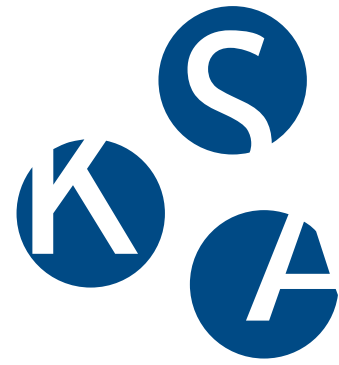

Keith Shuttleworth
& Associates

Technical Data

Sample connection	1/2" Tri-Clamp [®] compatible
Cooling water connections	1/2" BSP or NPT options
Coil surface area	0.113 m ² (1.217 ft ²)
Coil design pressure	115 barg (215 psig)
Shell dimensions	76.3 mm dia. x 250 mm high
Shell design pressure	110 barg (145 psig)
Weight	2.0 kg (4.4 lbs)
Capacities (approximate)	*Steam 160 ml/minute *Water 500 ml/minute

*Assumes cooling water at 20°C and flow @ 6 litres/minute

¹ Pressure/temperature is dependent upon Tri-Clamp[®] & seal suppliers specification.

SQ2 Portable Version

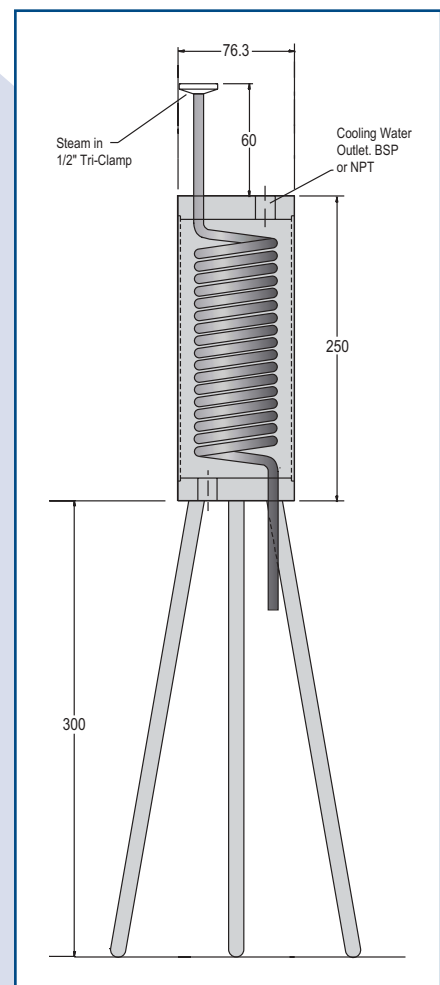

SQ2 Fixed Version

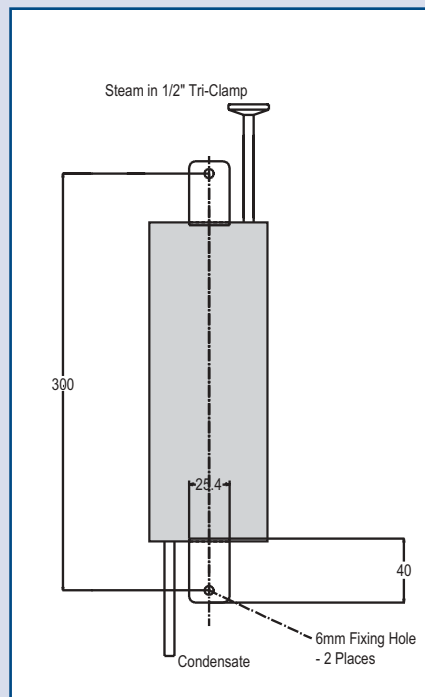
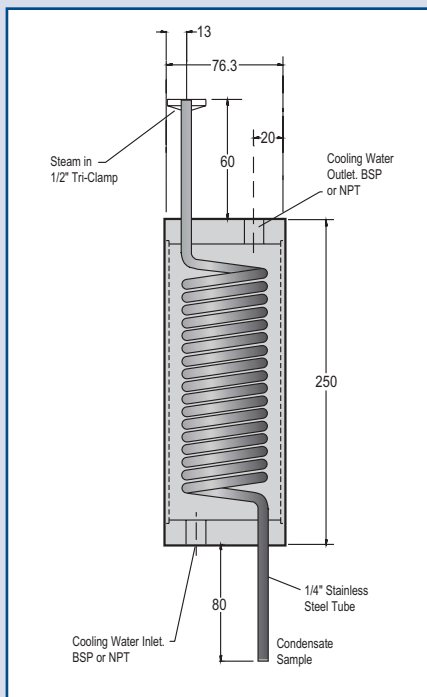

General arrangement

Mounting brackets

(all dimensions are in mm)

Keith Shuttleworth & Associates Ltd
Unit D5, Basepoint
110 Butterfield, Great Marlings
Luton
LU2 8DL
Tel: +44 (0)1582 433 723
Fax: +44 (0)207 1173251
Email: info@samplecooler.co.uk web: <http://www.samplecooler.co.uk>